



Installation Instructions and Homeowner's Manual



HYDRA REVOLUTION

Models:

HYDRAR15-E2401M

HYDRAR18-E2401M

HYDRAR20-E2401M

HYDRAR24-E2401M

HYDRAR27-E2401M

HYDRAR29-E2401M

ELECTRIC BOILER ELECTRONIC CONTROL



Manufactured by:

Dettson Industries Inc

3400, Industrial Boulevard
Sherbrooke, Qc, Canada, J1L 1V8

www.dettson.ca

Attention
Do not tamper with the unit
or its controls. Call a
qualified service technician.

INSTALLER / SERVICE TECHNICIAN :

Use the information in this manual for the installation / servicing of the boiler and keep the document near the unit for future reference.

HOMEOWNER :

Please keep this manual near the boiler for future reference.

TABLE DES MATIÈRES

SECTION 1	INSTALLATION	3
1.1	DANGER, WARNING AND CAUTION	3
1.2	HEATING WITH HOT WATER	3
1.3	DELIVERY	3
1.4	INSTALLATION	3
1.4.1	Positioning	3
1.5	CLEARANCES	4
1.6	DISTRIBUTION SYSTEM	4
1.7	INSTALLATION OF THE BOILER	6
1.8	ELECTRIC POWER SUPPLY	6
1.8.1	Connecting the Circulating Pump	6
1.8.2	Connecting the Thermostat	6
1.8.3	Connecting the Outdoor Sensor	6
SECTION 2	OPERATION	7
2	ADJUSTMENTS AND START-UP	7
2.1	MECHANICAL HIGH LIMIT	7
2.2	ELECTRONIC CONTROL	7
3	SECTION - MAINTENANCE	11
4	SECTION - INFORMATION	11
5	SECTION - TECHNICAL DATA	12
6	SECTION - REMPLACEMENT PARTS	17

INDEX DES TABLEAUX

Table 1.	Minimum clearances to combustible materials..	4
Table 2.	Hydra Revolution – Technical specifications...	12
Table 3.	Parts list	18
Table 4.	Parts list	20

INDEX DES FIGURES

Figure 1:	Mounting configurations	4
Figure 2:	Boiler components	5
Figure 3:	Power Stealing Thermostat Resistance	6
Figure 4:	Navigation in Menus	9
Figure 5:	Modulation in function of the exterior temperature.....	10
Figure 6:	Boiler Dimensions	13
Figure 7:	Typical Diagram of a Single Zone Installation .	14
Figure 8:	Multi-zone Diagram with more than one Circulator.....	14
Figure 9:	Multi-zone diagram with Motorized Valves.....	15
Figure 10:	Dual-energy installation.....	15
Figure 11:	Electrical Diagram.....	16
Figure 12:	Exploded Vue (3-4 elements).....	17
Figure 13:	Exploded Vue (5-6 elements).....	19

SECTION 1 INSTALLATION

1.1 DANGER, WARNING AND CAUTION

The words DANGER, WARNING and CAUTION are used to identify the levels of seriousness of certain hazards. It is important that you understand their meaning. You will notice these words in the manual as follows:



DANGER

Immediate hazards which **WILL** result in death or serious injury.



WARNING

Hazards or unsafe practices which **CAN** result in death or injury.

CAUTION

Hazards or unsafe practices which **CAN** result in personal injury, product or property damage.

1.2 HEATING WITH HOT WATER

Your HYDRA REVOLUTION electric boiler was carefully assembled and checked in our plant, so that it will deliver warmth and comfort to your home for many years to come.

This manual is intended to provide the necessary information for the installation of the unit, how it functions and explains security measures which are particular to this type of equipment.

It is essential that the persons installing, operating or adjusting the boiler carefully read this manual, in order to completely understand and be familiar with the procedures to be followed.

Any questions relative to the operation, maintenance or guarantee should be directed to the company where the equipment was purchased.

Upon completion of the installation, this manual should be placed back into its original envelope and kept near the boiler for future reference.

1.3 DELIVERY

Upon delivery of the boiler, check the nameplate to be sure that you have received the model with the correct rating and proper voltage.

The following items are supplied with the unit:

- A pressure relief valve, adjusted to 30 psi;
- A drain valve;
- An exterior probe for modulation;
- A ¼" cap to cork the tapped hole between the elements in the case the boiler is installed in sideways.
- A ¼"NPT coupling if unit is installed upright position.
- Two 1" X ¾" reducer for drain valve and pressure relief valve.

1.4 INSTALLATION



WARNING

The installation of this unit must be performed by a qualified technician and it must conform to the standards and regulations in force as well as the Canadian Installation Code for Hydronic Heating Systems CSA B214-01.

1.4.1 Positioning

The unit must be installed in an area that is dry, non-corrosive, without excessive dust, well ventilated and where the ambient temperature does not exceed 27°C (80°F).

The boiler can be installed using the included mounting brackets. First, unfold the four tabs on the back panel of the boiler. Position the top bracket and secure it to a wall. Place the boiler on the top bracket and then secure the bottom. Finally, use self-tapping screw to secure the tabs to the bracket. **Ensure that the unit is well fixed on the wall utilizing the 2 mounting brackets.**

The boiler can be installed in 5 possible configurations as shown in figure 1.

Ensure that it is installed level and that the clearances indicated in Table 1 are respected.

Figure 1: Mounting configurations

*The arrows represent the direction of the water flow

Mounting positions
Positions de montage

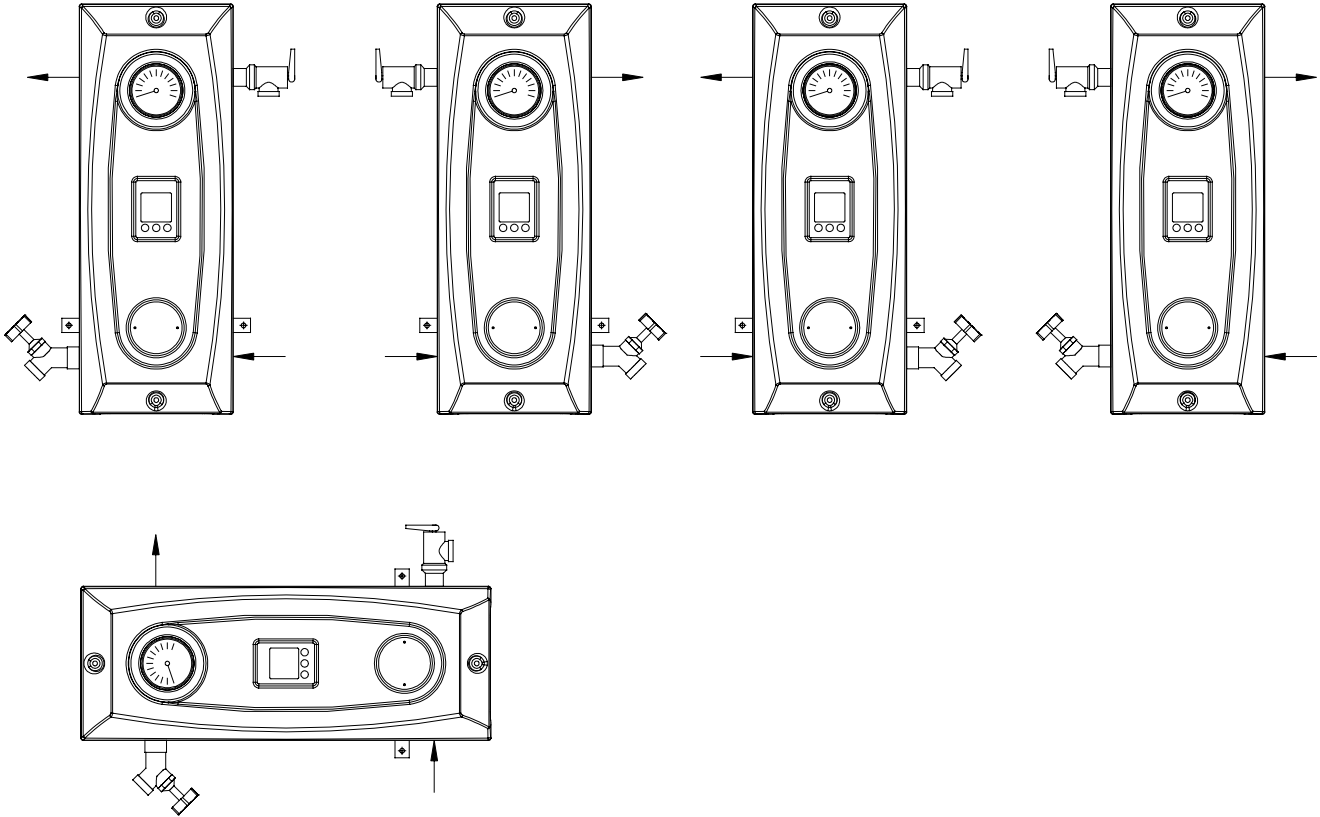

1.5 CLEARANCES

The following clearances should be provided for the servicing of the unit:

Table 1. Minimum clearances to combustible materials

LOCATION	CLEARANCE
Top (access to elements)	13 1/4" (34 cm)
Sides	4" (10 cm)
Bottom	0
Front*	0
Back	0

* If the boiler is in an enclosure, provide a door or a removable panel in front to access the control panel.

1.6 DISTRIBUTION SYSTEM

The proper functioning of your heating system is directly related to the quality of the plumbing installation. Therefore, the entire installation must be performed by qualified technicians.

See Figure 2 for the functions of the various boiler components.

The heating system must be set-up to operate at a maximum pressure of 28 psi and the operating temperature may range from 15°C to 88°C (60°F to 190°F).

Figure 2: Boiler components

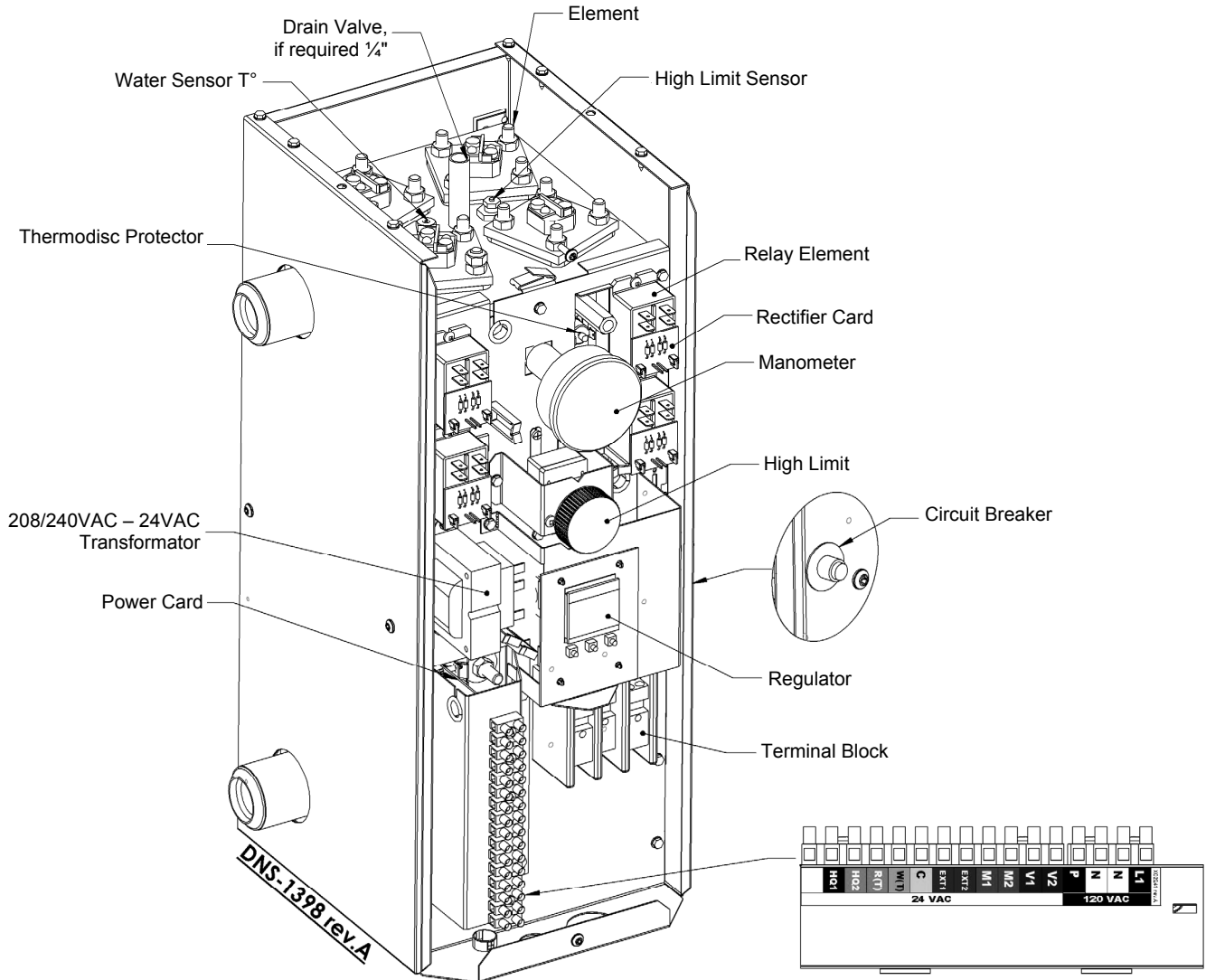

Freeze protection (when required)

WARNING

Only propylene glycol may be used in this hydronic heating system, to prevent freezing. It is recommended to add a maximum of 50% of propylene glycol mixture to ensure proper operation.

Do not use automotive anti-freeze, ethylene glycol or any undiluted anti-freeze.

If the above recommendations are not followed, severe personal injury, death or substantial property damage can result.

All installations must include the following items:

- 1 pressure regulator, adjusted to 12 psi, must be installed between the boiler and the main water supply in the building;
- 1 expansion tank, pre-pressurized to 12 psi and of appropriate size;
- 1 or more automatic air purge valves;
- 1 or more circulating pumps of appropriate capacity.

CAUTION

To avoid water damage and/or scalding due to relief valve operation, a discharge line must be connected to the valve outlet and run to a drainage area. The discharge line shall be installed in such a way that it will allow for the complete drainage of the valve and the discharge line.

1.7 INSTALLATION OF THE BOILER

At the time of installation, the following steps should be followed. Refer to Figure 5,6,7,8 and 9.

1. Choose an appropriate location. Mount the boiler securely on the wall, with the help of the mounting plate. Ensure that it is level and that the minimum clearances are observed;
2. Install the drain valve and the safety valve according to the mounting configuration as shown in Figure 1;
3. An air vent should be installed on the unit if installed upside position; in horizontal mounting position, cork the hole with the ¼" cap provided.
4. Install the water supply and return piping with the 1" NPT fitting;
5. The heating supply line must include:
 - a. 1 circulator along with 2 maintenance valves;
 - b. 1 automatic pressure reducing valve adjusted to 12 psi, with a shut-off valve on the return water line;
 - c. 1 expansion tank;
 - d. 1 automatic vent.
6. In order to ensure satisfactory water flow, the friction in the piping system must not exceed the capacity of the circulator;
7. After having completed all piping connections, run water through the system and purge the air. The automatic vent should be in operation.

Note: Remove the plastic cover and check to see if the elements are watertight.

1.8 ELECTRIC POWER SUPPLY

All electrical wiring must conform to the standards and regulations in force and the Canadian Electrical Code CSA C22.1.

Electrical power to the boiler must come from a 120/240V 60 Hz or 208V 60 Hz, single phase, 3-wire, grounded circuit, protected by an appropriately sized breaker, based on the total rating of the boiler. When using 208V, change the connector's position at the primary of the transformer. Refer to the boiler nameplate and the technical specifications in this manual to select the proper breaker and wire size. Use cable rated at 60°C or higher.

For models with a power of 24KW and above, two separate conductors are required. **Make sure to turn off both circuits when working in the appliance.**



WARNING

Fire Hazard.

The conductor sizing must conform to the last edition of the local or national codes.

Failure to follow this rule can result in death, bodily injury and/or property damage.

Power supply to the unit can be made using copper or aluminum wires. The wire size must be decided in accordance to unit power consumption, the over current protection type and capacity, the wire type and length, and the environment where the unit is installed. If an aluminum wire is used, other precautions (such as the use of a DE-OX inhibitor) must be taken to insure the conformity of the installation. In all cases, all the factors affecting the wire gauge must be considered and the installation codes followed.

The exterior of the unit must have an uninterrupted ground to minimize the risk of bodily harm. A ground terminal is supplied with the control box for that purpose.

In the event that wires inside the unit require replacement, these must be as same type as originals. (Copper wiring only)

1.8.1 Connecting the Circulating Pump

Connect the circulating pump on 120V connections points identified N for neutral and P for controlled 120V output in the control panel as shown in Figure 2. The electronic control is designed to operate the circulator on thermostat demand, with a heat purge delay at the end of heating cycle or continuous flow. Refer to the electronic control section to learn how to configure this function.

1.8.2 Connecting the Thermostat

A 150 OHMS – 10W must be installed if a power stealing thermostat is used. This resistance must be connected to C-W as shown in Figure 3:

Figure 3: Power Stealing Thermostat Resistance

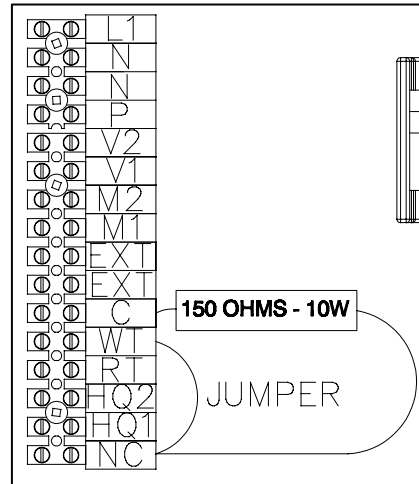

Single heating zone

Connect the low voltage thermostat to C(T)-W(T) terminals located inside the control panel. See Figure 4.

Multiple heating zones

Connect the contacts of the motorized valves or pump controls to C(T)-W(T) terminals inside the control panel. See Figure 5 and 6.

1.8.3 Connecting the Outdoor Sensor

Mount the sensor on an outside wall, protected from direct sunlight, so that it will accurately measure the outside temperature. Install 2 #20 wires between the outdoor sensor and the terminals identified as EXT1 and EXT2 inside the control panel of the boiler.

SECTION 2 OPERATION

2 ADJUSTMENTS AND START-UP

CAUTION

The boiler must be filled with water and all air purged from the system, before turning on the power.

CAUTION

If the power is turned on before the boiler is filled with water, the elements will become seriously damaged.

1. Adjust the set point of the boiler on the electronic control. See control section for adjustments.
2. Turn on the power, set the thermostat at 30°C (85°F). The circulator should start as well as the electrical elements in sequence with a 12 seconds delay;
3. The circulator stays on for as long as there is a call for heat except if differently configured on the electronic control.

2.1 MECHANICAL HIGH LIMIT

Mechanical High Limit Control

The mechanical limit aquastat must be set 20°F above the set point temperature on the electronic control.

Manual reset high limit control

Disconnect the unit before resetting the high limit. The manual reset high limit is set at 100°C (212°F). To reset this protection, the boiler needs to cool down. Then the red button shall be pressed using a pen or screwdriver.

2.2 ELECTRONIC CONTROL

Display and electrical controller:

PUMP	: OFF
SET P	: 149.0 °F
TARGET	: 149.0 °F
T° IN	: 62.5 °F
T° OUT	: UNUSED
Cmd	: 0%

Pump: Shows the state of the pump.
Set P: Indicates the temperature set point.
Target: Indicates the target temperature.
T° in: Temperature inside of the device.
T° out: Temperature outside of the device
Cmd: Indicates the percentage of power sent to the elements

From this screen and by pressing the directional buttons, the user can switch from the various menus available and press the central button to access the desired menu.

These menus are the consumption menu, the alarm menu, the configuration menu and the installer menu.

Consumption:

The consumption menu shows an approximated value of the power consumed by the boiler since it was last reset.

CONSUMPTION
APPROX: 13.2kWh
12 hours ago
press o to reset

Consumption is written in kilowatt hour and time since last reset is given in hours or in days.

As shown on the screen, pressing the central button will reset the time and power consumed.

Alarms:

Some events may alter the functionality of the device in an undesired manner. These events trigger alarms in the system that remains stored in the device's memory. Reasons for alarms are: troubles with the internal or the external heat sensor, problems with elements and overheating.

In case of alarm, the controller's screen will be illuminated by a flashing red light. It is strongly advised that you tell an installer about this issue.

Using the left and right buttons, the arrow on the screen can be moved and the central button will allow the user to activate the element pointed by it.

ALARM
-> CURRENT
PAST
CLR. ALARM
BACK

Current: Indicate the alarms currently afflicting the device.

Past: Shows an history of the alarms triggered on the device.

Clear alarm: Ends alarms that still appear active on the device.

ALARM
Error #1
Err. int. sensor
2 hours ago

The past alarm function allows you to revisit the previous 25 alarm messages and an approximated time span since they happened. The arrow buttons allow the user to scroll through the alarm reports and the central button allows them to return to the alarm menu.

Configuration:

The configuration menu's purpose is to allow the user to adjust settings linked to the interface, such as the temperature's units and the language.

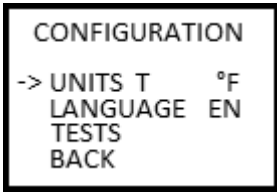

Units: allows switching between Fahrenheit and Celsius degrees.

Language: allows switching the displayed text between French and English.

Important: Access to the Tests tab appearing on the controller's screen is protected by a password. Under no circumstances should a user try to access it. This function is used at the Dettson factory to test the Hydra Revolution before it is shipped to a distributor. If the user manages to enter the correct password the machine will be stuck in the test function. To exit the test function, the machine must be shut down, it will then return to the main screen after being subsequently turned on.

Installer:



The installer menu's goal is to make the installer's work easier. This menu is protected by a password that can be found on the electrical schematic glued to the plastic case of the Hydra Revolution.

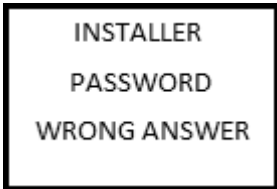

The password consists of a combination of characters entered with the three buttons of the Hydra (left, center, right then center).



The user shouldn't try to gain access to this menu as it is used to program the behaviour of the device.

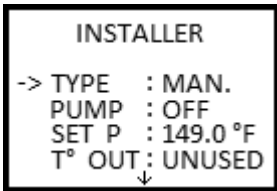

Type: Gives a preset value to the temperature set point. Mass, Plinth, Light and Cast Iron are preset values for determining temperature ceil. Manual allows the installer to manually choose the set point.

Pump: Choose the way to drive the pump. Off means the pump will activate only when there is a demand from the thermostat. "On" means that the pump will always be active. 20 Seconds indicate that the pump will deactivate 20 seconds following the end of a heating demand from the thermostat.

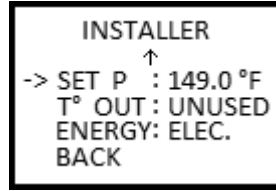

Set P: Set the target temperature the device will try to reach upon the reception of a signal from the thermostat.

T° ext: Allows the device to know if an external sensor is being used.

Energy: Sets the way the machine will manage its energy. "Dual" tells the device that upon receiving a signal from the electrical network, it will transfer the heating demand exclusively to an oil boiler (this is mostly the case when the energy provider is Hydro-Quebec). "Oil" means the Hydra will be completely bypassed and an oil boiler will be used to produce heat instead. "Elec." means there won't be a dual energy system and thus the Hydra Revolution will be the only source of heat.

Boost Mode:



The boost mode menu allows the user to raise the boiler's temperature set point by 10 degrees Fahrenheit during 24 hour. Press the central button while in this menu to activate or deactivate this measure.

Figure 4: NAVIGATION IN MENUS

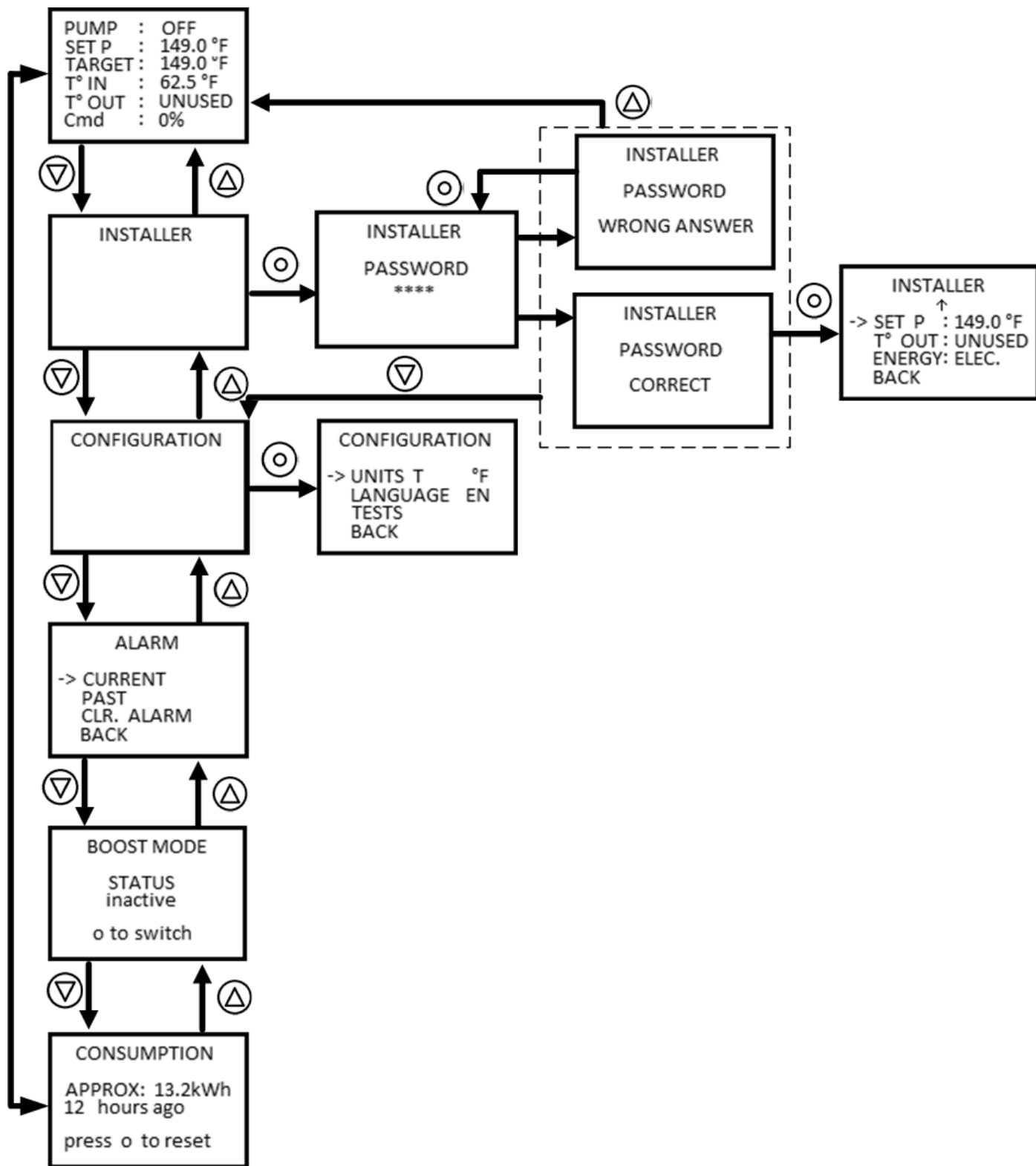
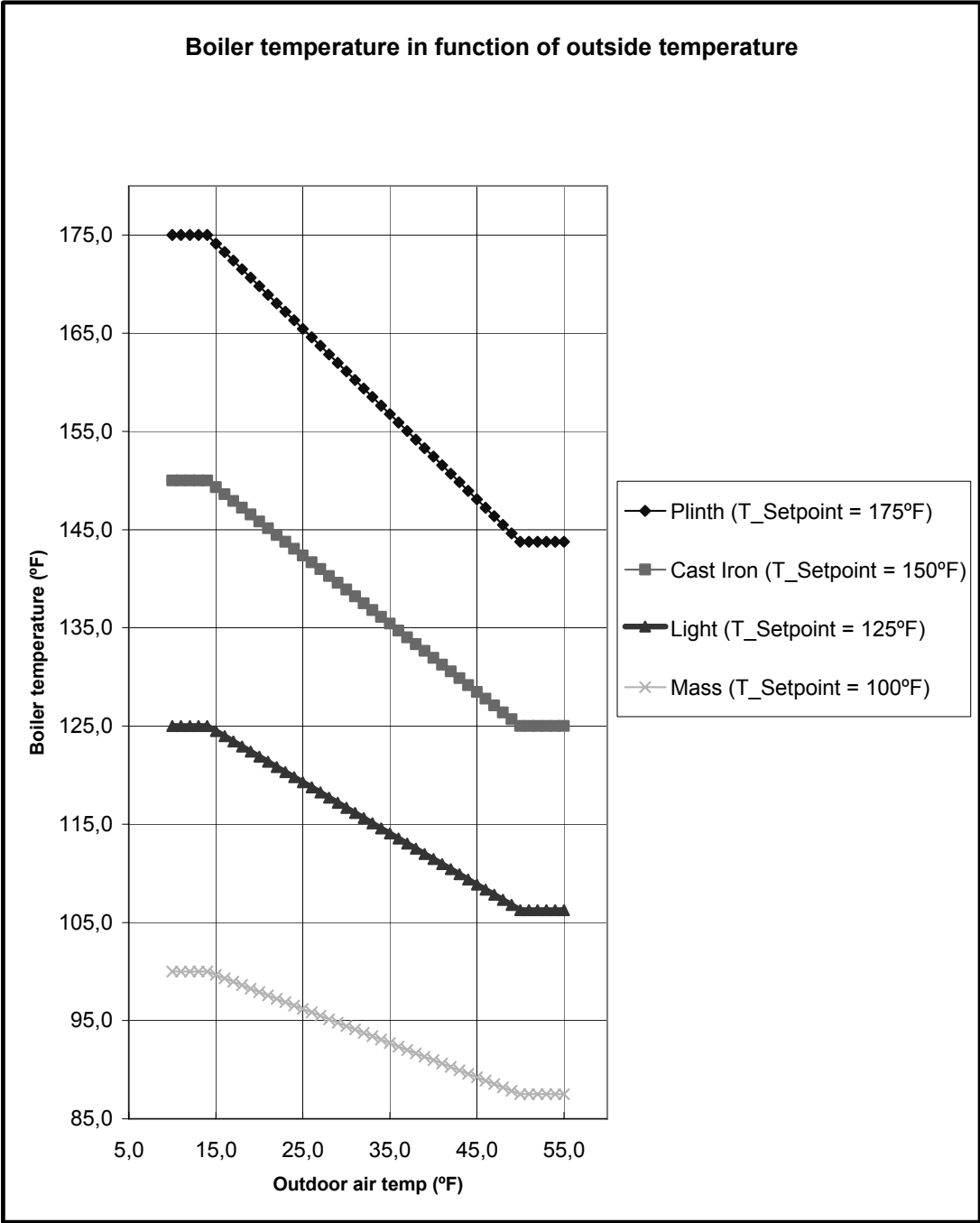

Figure 5: MODULATION IN FUNCTION OF THE EXTERIOR TEMPERATURE



3 SECTION - MAINTENANCE

The property owner has the following responsibilities:

- a. To maintain the area around the boiler clean at all times and free from combustible and highly flammable material;
- b. To ensure that the ambient air at the boiler is not excessively dusty or humid;
- c. To have all water leaks repaired in the system as they arise.
- d. To ensure that the ambient temperature in the area where the unit is installed does not exceed 27°C (80°F).

CAUTION

The boiler guaranty may be invalidated if: water leaks in the system are not repaired; the boiler is used as a source of domestic hot water or a significant amount of new water or air is introduced into the system.

It is recommended that the boiler be purged annually, in order to eliminate sediment and sludge that may have accumulated at the bottom of the boiler and covered the heating elements.

Procedure:

1. Let the boiler cool down;
2. Close the maintenance valves, which are installed at the water inlet and outlet of the boiler. N.B.: It is not recommended to drain the water from the heating pipe system;
3. Hook-up a garden hose to the drain valve and place it close to a floor drain;
4. Open the purge valve until the water comes out clean and clear;
5. Close the valve.

It is recommended to perform a visual inspection of the boiler electrical compartment annually, during the heating season. The items to check are the water tightness of the elements, signs of overheating of the electrical components and the wiring. Corrective measures must be undertaken as required, as soon as possible.

Defective components should always be replaced with the Original Equipment Manufacturer's parts.

4 SECTION - INFORMATION

Model: _____ Serial number: _____

Installation date of the electric boiler: _____

Service telephone # – Day: _____ Night: _____

Dealer name and address: _____

5 SECTION - TECHNICAL DATA

Table 2. Hydra Revolution – Technical specifications

Model Number	POWER (KW@240V)	POWER (KW@208V)	Electric element #1 (kW)	Electric element #2 (kW)	Electric element #3 (kW)	Electric element #4 (kW)	Electric element #5 (kW)	Electric element #6 (kW)	Consumption (Amp @208V / @240V)	VOLTAGE - FREQUENCY - PHASE	General information	Supply - Return	Overall Dimensions (W x D x H) in	Shipping Weight (Lbs)
HYDRAR15-E2401MA	15	11,3	5	5	5	NA	NA	NA	54 / 62	208/240V - 60Hz - 1		1" NPT Female	8,2 x 11,3 x 21,4	65
HYDRAR18-E2401MA	18	13,5	4	5	4	5	NA	NA	65 / 75					
HYDRAR20-E2401MA	20	15,0	5	5	5	5	NA	NA	72 / 83					
HYDRAR24-E2401MA	24	18,0	4	5	5	5	5	NA	86 / 100					
HYDRAR27-E2401MA	27	20,3	4	4	5	4	5	5	97 / 112					
HYDRAR29-E2401MA	29	21,8	4	5	5	5	5	5	104 / 120					
In all cases, refer to applicable local and national codes												11,2 x 11,3 x 21,4	85	

Figure 6: Boiler Dimensions

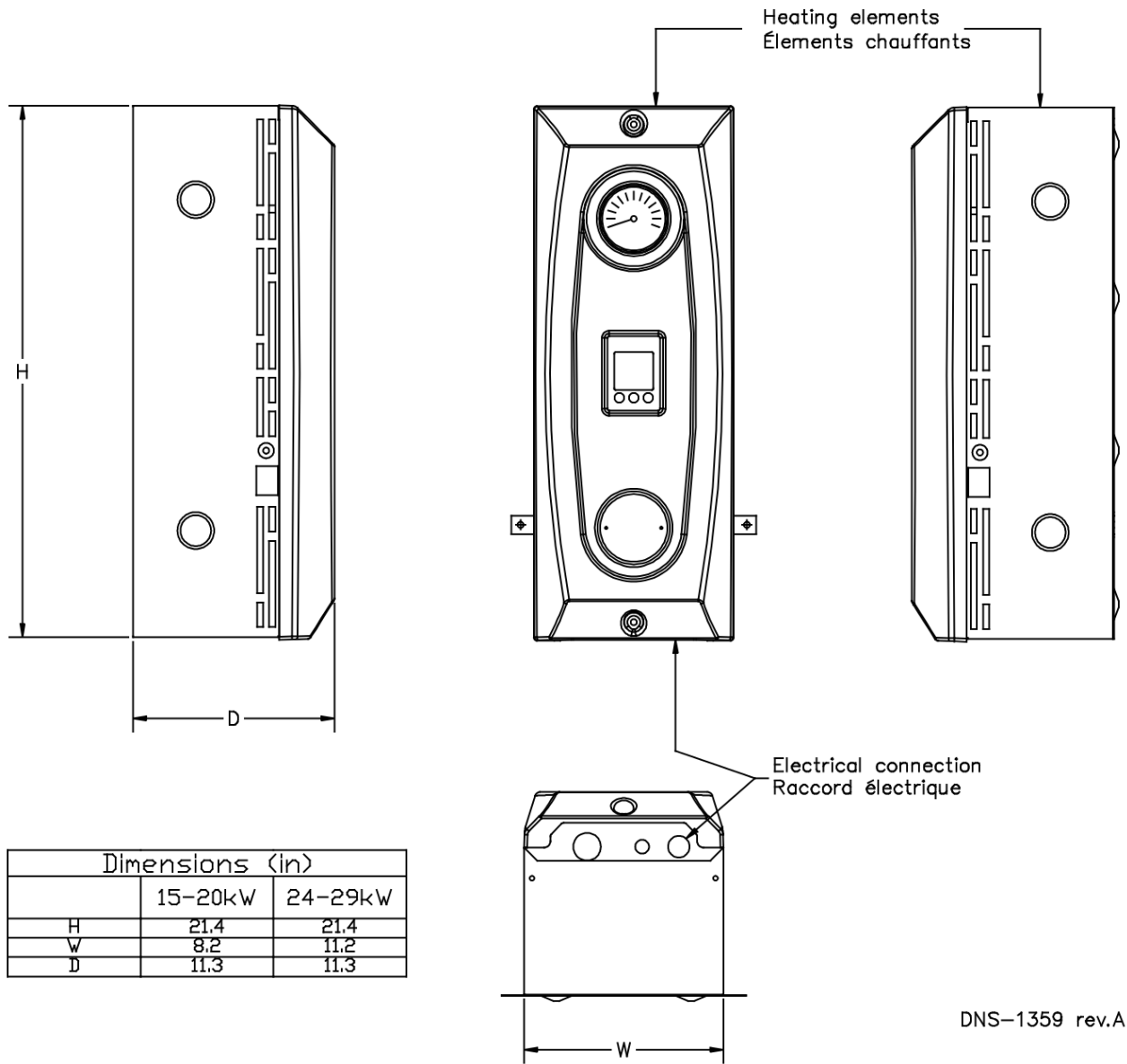

DNS-1359 rev.A

Figure 7: Typical Diagram of a Single Zone Installation

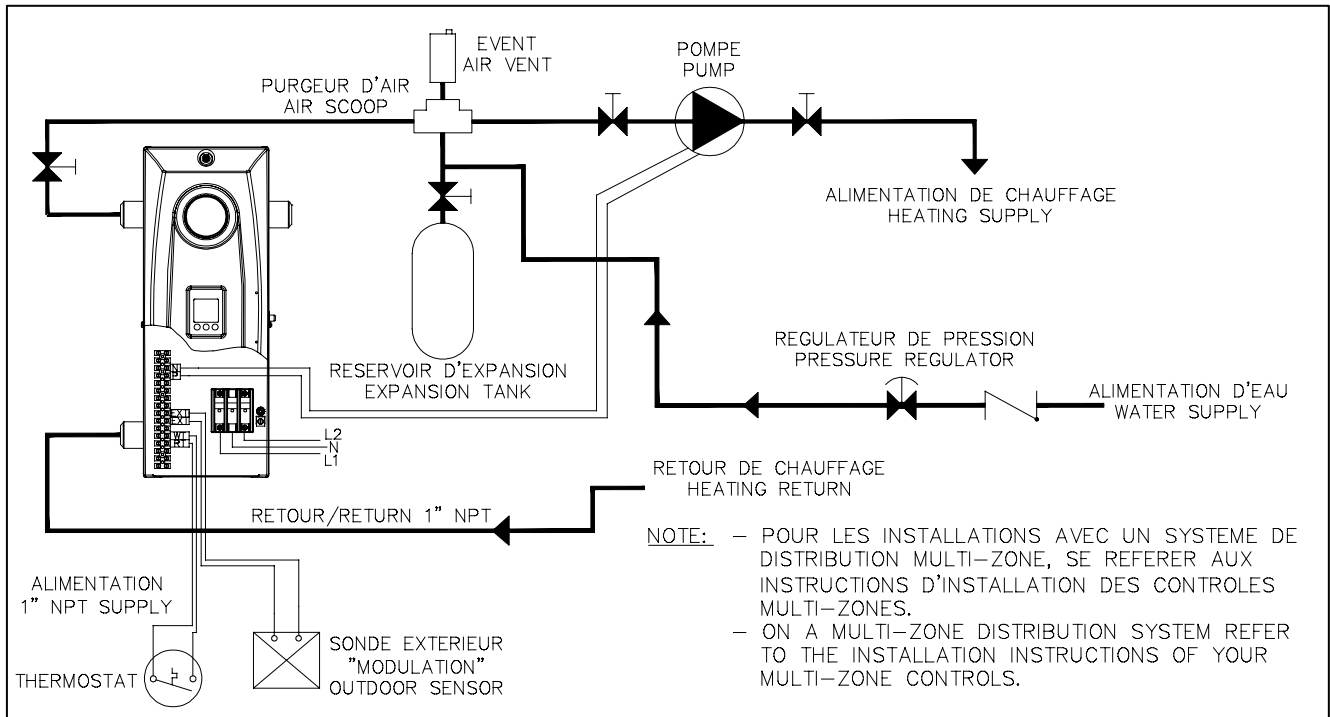

Figure 8: Multi-zone Diagram with more than one Circulator

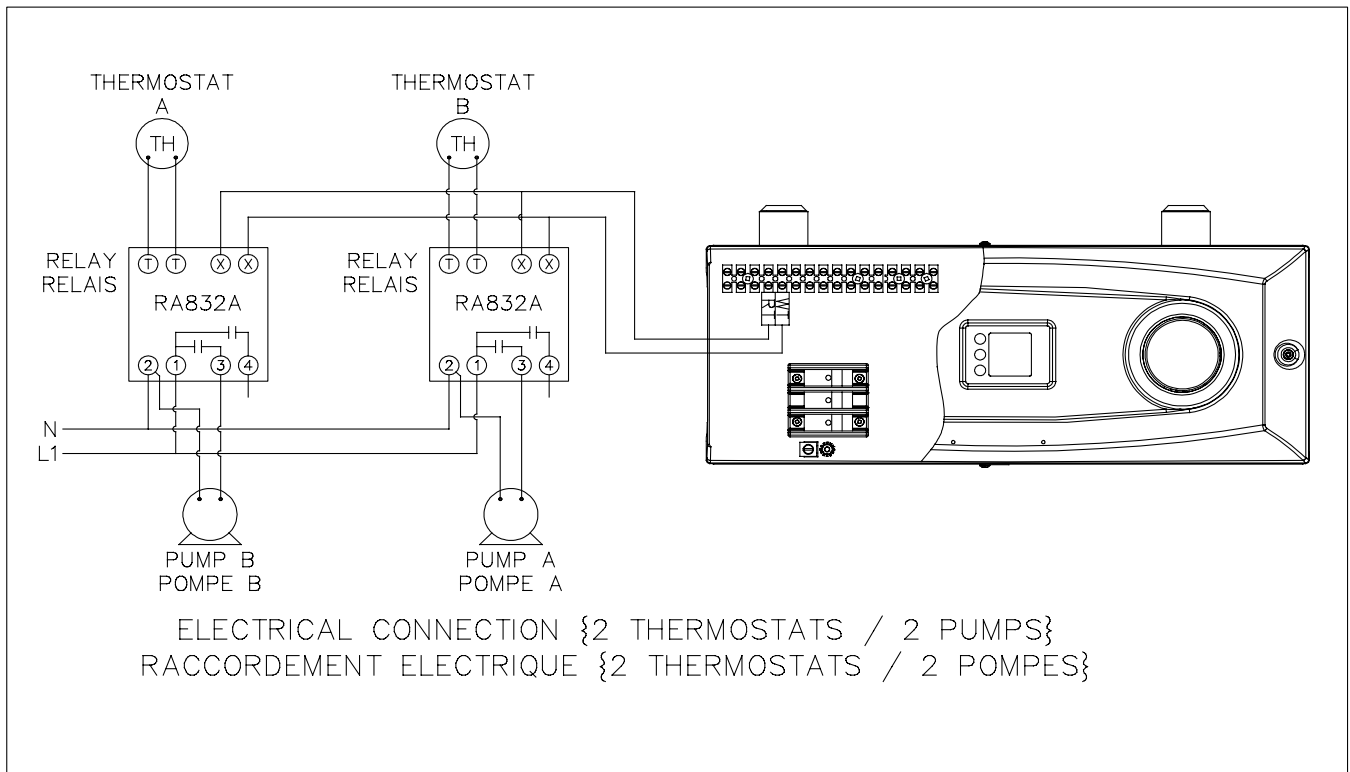

Figure 9: Multi-zone diagram with Motorized Valves

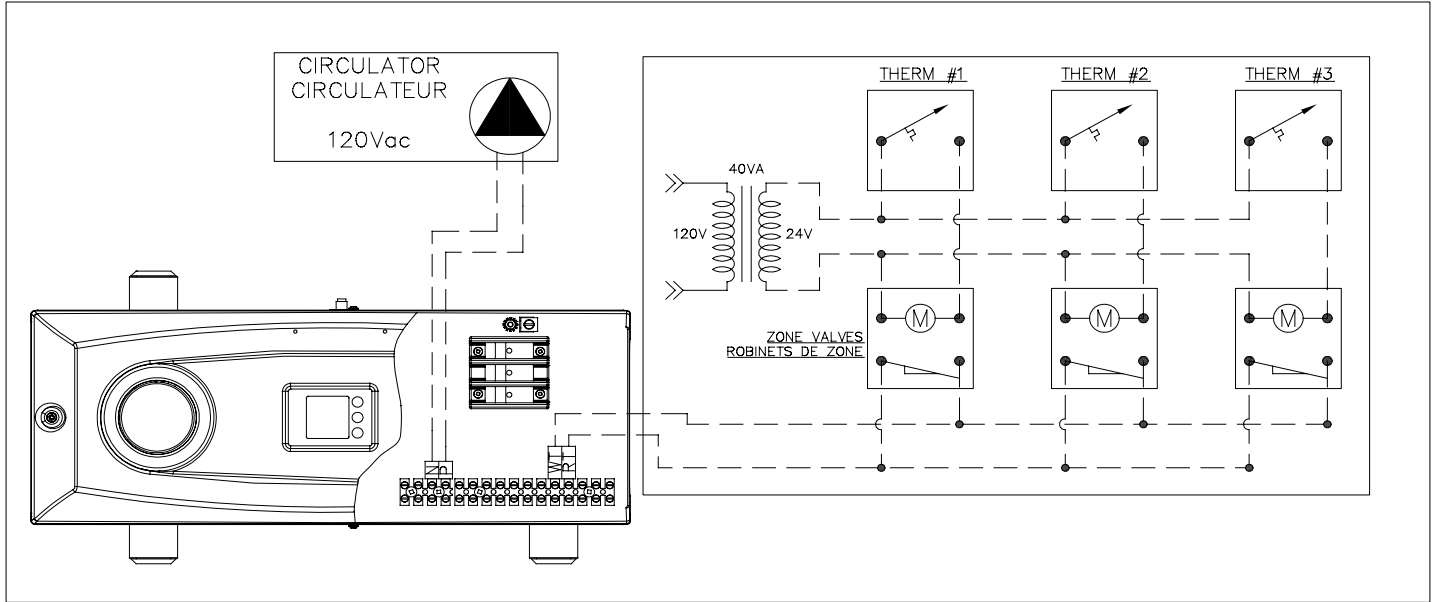
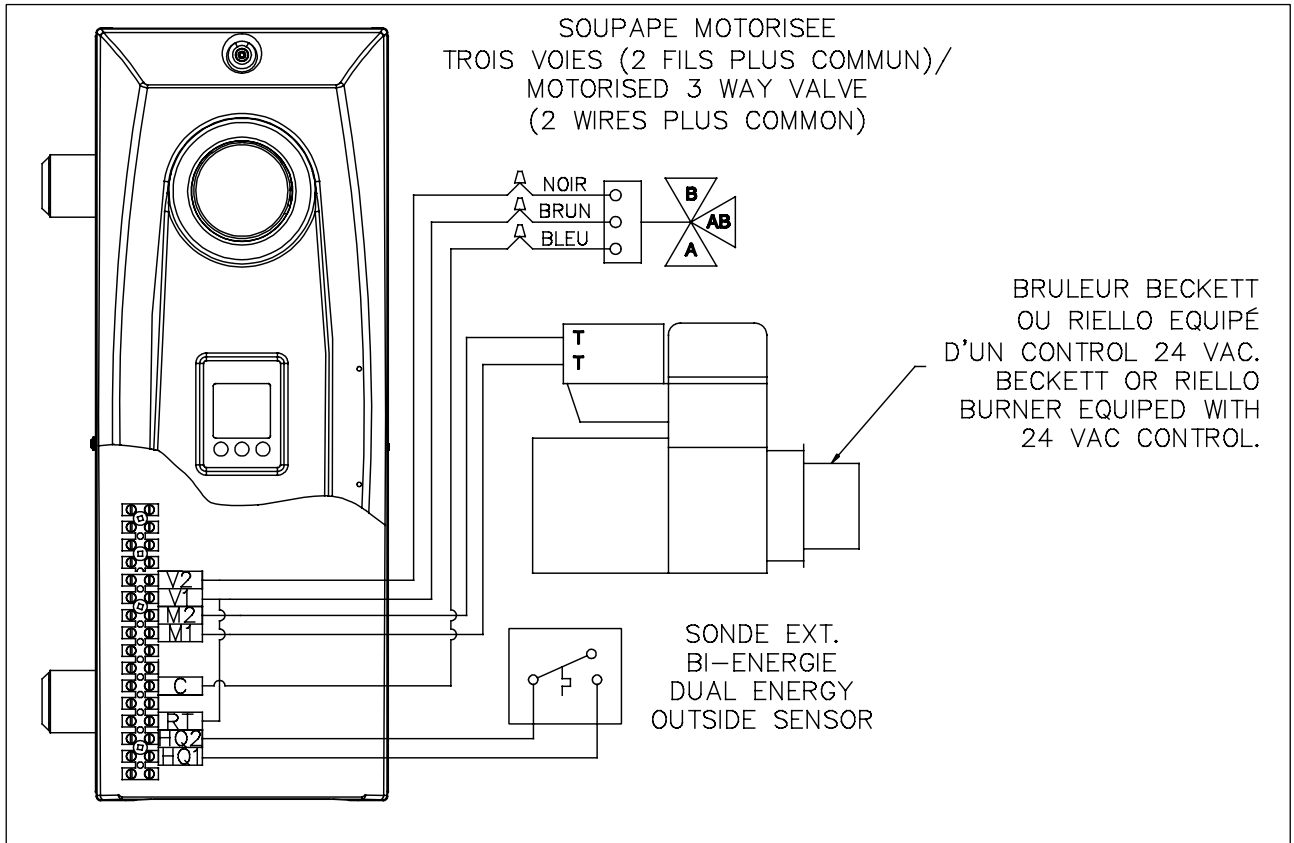

Figure 10: Dual-energy installation



6 SECTION - REPLACEMENT PARTS

Figure 12: Exploded Vue (3-4 elements)

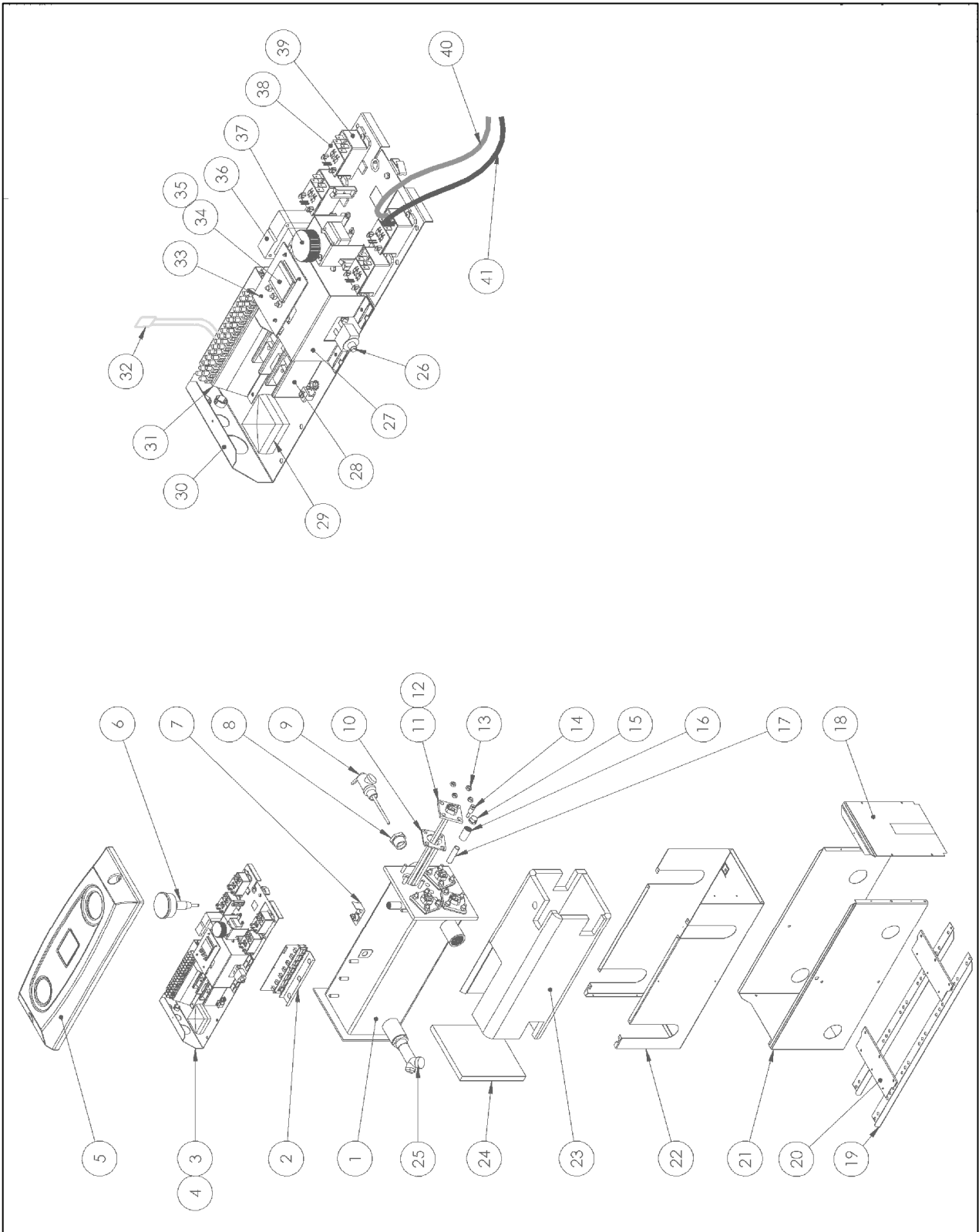

Table 3. Parts list

ITEM	Part Number	15 kw	18 kw	20 kw	Description	Comments
1	B04167-01	1	-	-	Boiler assembly	Boiler only (3 holes)
	B04167-02	-	1	1		Boiler only (4 holes)
2	B04181	1	1	1	Triac support assembly	Support and power card
3	B04172	-	1	1	Wiring panel assembly	Panel with wirings included
4	B04171	1	-	-		
5	B04174	1	1	1	Cover assembly	Cover, cosmetic and wiring diagram included
6	R02L007	1	1	1	Manometer LG 0-75PSI 1/4NPT	
7	B04180	1	1	1	Thermodisc support assembly	
8	G08F005	2	2	2	Reducer 1 x 3/4 Black	
9	G11F025	1	1	1	Relief valve 30# 3/4m x 3/4f	
10	B03970	3	4	4	Sealing gasket element	
11	L99H015	3	2	4	Element (5 kw)	
12	L99H014	-	2	-	Element (4 kw)	
13	F07F015	16	16	16	Hexagonal nut 5/16-18 brass	
14	R02Z008	1	1	1	H2998 24LG temp sensor probe	
15	G16G004	1	1	1	Female cap 1/4" NPT Black	
16	G03F001	1	1	1	Coupling 1/4-18 NPT	
17	G01G002	1	1	1	Nipple SD 1/4"NPT x 2" Black	
18	B04178	1	1	1	End plate assembly	Panel and warning label included
19	B03952	2	2	2	Wall bracket	
20	B04201	2	2	2	Machine bracket	
21	B04198	1	1	1	Jacket	
22	B04193	1	1	1	Cabinet	
23	B04202	1	1	1	Contour insulation	
24	B04203	1	1	1	End insulation	
25	G11Z002	1	1	1	Drain Faucet 3/4"m	
26	L01J001	1	1	1	Breaker	
27	B04194	1	1	1	Control support	
28	L99F007	1	1	1	Terminal block	
29	A20015	1	1	1	Outdoor sensor -12 C	
30	B04204	1	1	1	Electrical panel	Panel only
31	B04182-01	1	1	1	Triac protector assembly	
32	A00421	1	1	1	Ext. sensor electrical wiring	
33	F14G007	4	4	4	Card sleeve PC .315 CBDLS525	
34	R99G020	1	1	1	Dettson control 2013	Control only
35	B04205	1	1	1	Electronic wiring	
36	L01F010	1	1	1	Transformer 208/240/120	
37	B04184	1	1	1	Aquastat support assembly	Aquastat, bottom and support included
38	R99G006	3	4	4	Rectifier control	
39	L01H030	3	4	5	Relay DPST 22VDC	
40	A20009-07	3	4	4	Red wire element	
41	A20009-06	3	4	4	Black wire element	

Figure 13: Exploded Vue (5-6 elements)

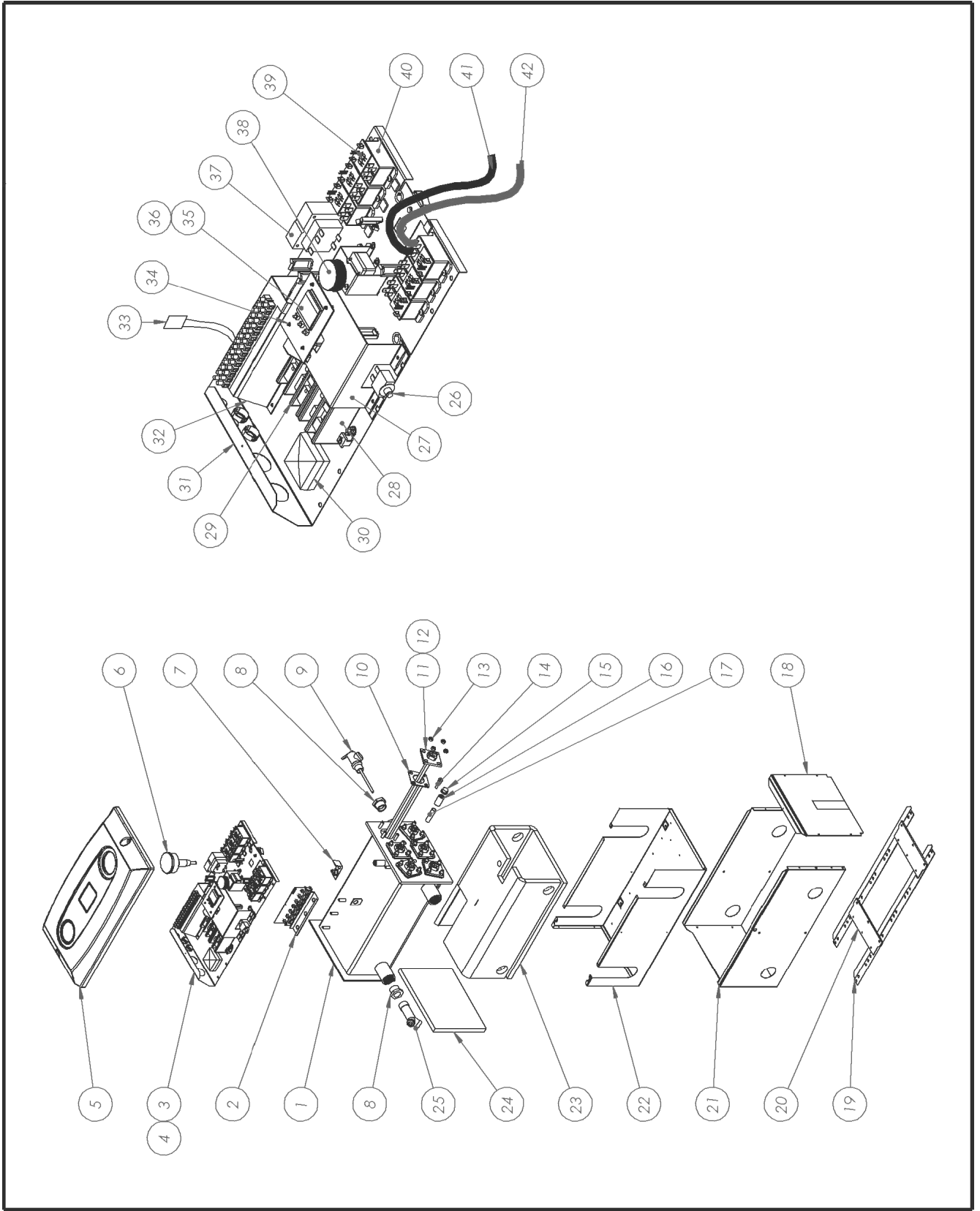

Table 4. Parts list

ITEM	Part number	24 kw	27 kw	29 kw	Description	Comments
1	B04169-01	1	-	-	Boiler assembly	Boiler only (5 holes)
	B04169-02	-	1	1		Boiler only (6 holes)
2	B04181	1	1	1	Triac support assembly	Support and power card
3	B04187	-	1	1	Wiring panel assembly	Panel with wirings included
4	B04186	1	-	-		
5	B04175	1	1	1	Cover assembly	Cover, cosmetic and wiring diagram included
6	R02L007	1	1	1	Manometer LG 0-75PSI 1/4NPT	
7	B04180	1	1	1	Thermodisc support assembly	
8	G08F005	2	2	2	Reducer 1 x 3/4 Black	
9	G11F025	1	1	1	Relief valve 30# 3/4m x 3/4f	
10	B03970	5	6	6	Sealing gasket element	
11	L99H014	1	3	1	Element (4 kw)	
12	L99H015	4	3	5	Element (5 kw)	
13	F07F015	20	24	24	Hexagonal nut 5/16-18 brass	
14	R02Z008	1	1	1	H2998 24LG temp sensor probe	
15	G16G004	1	1	1	Female cap 1/4" NPT Black	
16	G03F001	1	1	1	Coupling 1/4-18 NPT	
17	G01G002	1	1	1	Nipple SD 1/4"NPT x 2" Black	
18	B04179	1	1	1	End plate assembly	Panel and warning label included
19	B03952	2	2	2	Wall bracket	
20	B04201	2	2	2	Machine support	
21	B04177	1	1	1	Jacket assembly	
22	B04211	1	1	1	Cabinet	
23	B04217	1	1	1	Contour insulation	
24	B04218	1	1	1	End insulation	
25	G11Z002	1	1	1	Drain Faucet 3/4"m	
26	L01J001	1	1	1	Breaker	
27	B04215	1	1	1	Control support	
28	L99F008	1	1	1	Terminal block (2)	
29	L99F007	1	1	1	Terminal block (3)	
30	A20015	1	1	1	Outdoor sensor -12 C	
31	B04214	1	1	1	Electrical panel	Panel only
32	B04183-01	1	1	1	Triac protector assembly	
33	A00421	1	1	1	Ext. sensor electrical wiring	
34	F14G007	4	4	4	Card sleeve PC .315 CBDLS525	
35	R99G020	1	1	1	Dettson control 2013	Control only
36	B04206	1	1	1	Electronic kit	
37	L01F010	1	1	1	Transformer 208/240/120	
38	B04184	1	1	1	Aquastat support assembly	Aquastat, bottom and support included
39	R99G006	5	6	6	Rectifier control	
40	L01H030	5	6	6	Relay DPST 22 VDC	
41	A20009-06	5	6	6	Black wire element	
42	A20009-07	5	6	6	Red wire element	